

PARTICLES VELOCITY AND TEMPERATURE STATISTICAL MEASUREMENTS IN A D.C.
PLASMA JET

Vardelle A., Vardelle M., Baronnet J.M., Fauchais P.
Laboratoire de Thermodynamique - E.R.A. 539
U.E.R. des Sciences - 123 rue A. Thomas 87060 Limoges France

1. INTRODUCTION

The quality of a plasma sprayed coating is a complex function of the spraying conditions : electrical power input to the torch, nature and flow rate of various gases, powder sizes distribution, distance from the torch to the substrate and powder injection conditions.

These various factors have a direct influence on particles velocity and temperature distributions at their impact on the substrate. In particular the degree of particles spreading affects the particles cooling rate, the adhesion strength and the coating porosity.

Consequently the particles temperature and velocity knowledge allows to correlate the spraying conditions and the quality of the sprayed coating.

Particles velocity is measured by laser anemometry /1/with interferential arrangement and particles surface temperature by optical pyrometry /2/. Measurements have been performed on alumina powders.

2. PARTICLES VELOCITY

2.1 Experimental set-up (figure 1)

The beam of an argon-ion laser (1) ($\lambda = 5145 \text{ \AA}$, $p = 1,5 \text{ watt}$), equipped with a polarisation rotator (2), is split into two beams of equal intensity by a beam splitter (3) of double-prism type. The axis of the fringe pattern formed at the two beams intersection (4) may be rotated by a three flat mirror rotating device (6). The scattering volume (4) is imaged by a lens (7) onto a pin-hole ($\phi = 100 \text{ }\mu\text{m}$) put in front of an EMI 9863 photon counting photomultiplier (8) equipped with an interferential filter ($\Delta\lambda = 10 \text{ \AA}$, $\lambda = 5145 \text{ \AA}$). The sampling volume is approximatively a 1.3 mm diameter sphere. The fringe spacing-usually $102 \text{ }\mu\text{m}$ is accurately measured as follow : a micrometric scale is placed in the sampling volume overlapping the fringes ; their image is focused with a magnifying of 150 on a screen (9) by lenses (10) and retractable flat mirrors (11).

The signal processing system is a photon correlator (12) (Malvern K 7023). Signals-with very low signal-to-noise ratio may be extracted by this device which has allowed us to perform measurements even in the core of the plasma jet and even with very small particles.

2.2. Experimental results

Usual working conditions were :

arc intensity : 280 A
 power supplied to the gas (torch cooling losses subtracted) : 17 kW
 plasma gas composition : 0.17 g/s Ar + 0.60 g/s N₂ + 0.008 g/s H₂
 Statistic measurement is performed with about 25 000 instantaneous values.
 The powders injection point, located at 2 mm out from nozzle exit, is the axis origin.

The radial and axial distribution of axial velocity is showed on figure 2 for 18 μm size particles and for 22 m/s particles injection velocity ; the measured values dispersion is low on the torch axis (< 7 %) but increases with the radius r (~ 20 % at r = 9 mm).

Axial velocity is plotted on figure 3 versus particles injection velocity for various axial positions : the highest velocity is reached when the particles injection velocity range between 20 and 24 m/s.

The particles size influence is pointed out on figure 4 : axial distribution of axial velocity measured on the axis for various particles size.

Particles paths deduced from measured axial and radial velocities are plotted on figure 5 for different working conditions : plasma gaz composition 0.76 g/s N₂ + 0.011 g/s H₂ ; power supplied to the plasma 20 kW ; arc intensity : 290 A ; particles injection velocity 22 m/s. (for example at y = 140 mm and r = 16 mm, $\overline{V}_y = 180$ m/s and $V_r = 25$ m/s).

3. PARTICLES SURFACE TEMPERATURE

3.1 Experimental set-up (figures 1 and 6)

The particle surface temperature is measured from surface radiation which is a function of surface temperature but also of emissivity. The sampling volume (4) is imaged by two lenses (13) on to a pin-hole put in front of an RCA 31034 C cooled photomultiplier (14) equipped with a band-pass filter ($C.7 \mu\text{m} < \lambda < 1.05 \mu\text{m}$). The sampling volume is approximately a cylinder of 150 μm diameter with its axis perpendicular to the plasma jet axis.

The amplitude of current pulses generated by particles crossing the sampling volume is a function of particles size and shape, surface temperature, material emissivity and detection system arrangement. These signals are amplified, shaped and analysed by a multichannel analyser (15) which provides the histogram of pulses amplitude distribution (figure 6a). A previous calibration, needed to know the pulse amplitude versus surface temperature, is performed by simulation of particles of known diameter, velocity and temperature (figure 6b) : the tungsten ribbon lamp and the pin-hole simulate the particle while the chopper simulates its velocity.

3.2 Experimental results

An histogram of pulses amplitude distribution is shown on figure 7a. Taking into account the difference between the tungsten and alumina emissivities, the surface temperature histogram, plotted on figure 7b, is obtained. Some plasma jet areas at different temperatures are included in the sampling volume, so the histogram is relatively dispersed. The most probable temperature is taken as the representative temperature \overline{T}_S of the particles at the measured point.

\overline{T}_S axial distribution measured on the axis, is plotted on figure 8 : the plasma gas mixtures were respectively 0.17 g/s Ar + 0.52 g/s N₂ + 0.02 g/s H₂ for curve (1) and 0.17 g/s Ar + 0.60 g/s N₂ + 0.008 g/s H₂ for curve (2). It is worth noting that an increase of hydrogen proportion improves the particle melting yield by increasing plasma thermal conductivity.

The influence of particles injection velocity on \overline{T}_S axial distribution is pointed out on figure 9. When particles initial kinetic energy is too high or too low, only a few particles have axial paths and \overline{T}_S decreases.

4. CONCLUSION

The results are in good agreement with those deduced from the ESM observation of the coatings realized at the same measured points.

They should allow us on the one hand to increase the coating qualities on the other hand to work out a model of plasma-particle heat transfer.

Acknowledgments

The authors wish to thank-the "Division du Genie Isotopique" of C.E.A. and especially M. Yvars for their assistance.

REFERENCES

- /1/ Gouesbet G. - Thèse de Doctorat ès Sciences Physiques, Université de Rouen (1977).
- /2/ Kruszewska B., Lesinski J. - Revue de Physique Appliquée 13, 1209, (1977).
- /3/ Vardelle A. - Thèse de Doctorat de 3ème cycle - Université de Limoges (1979).

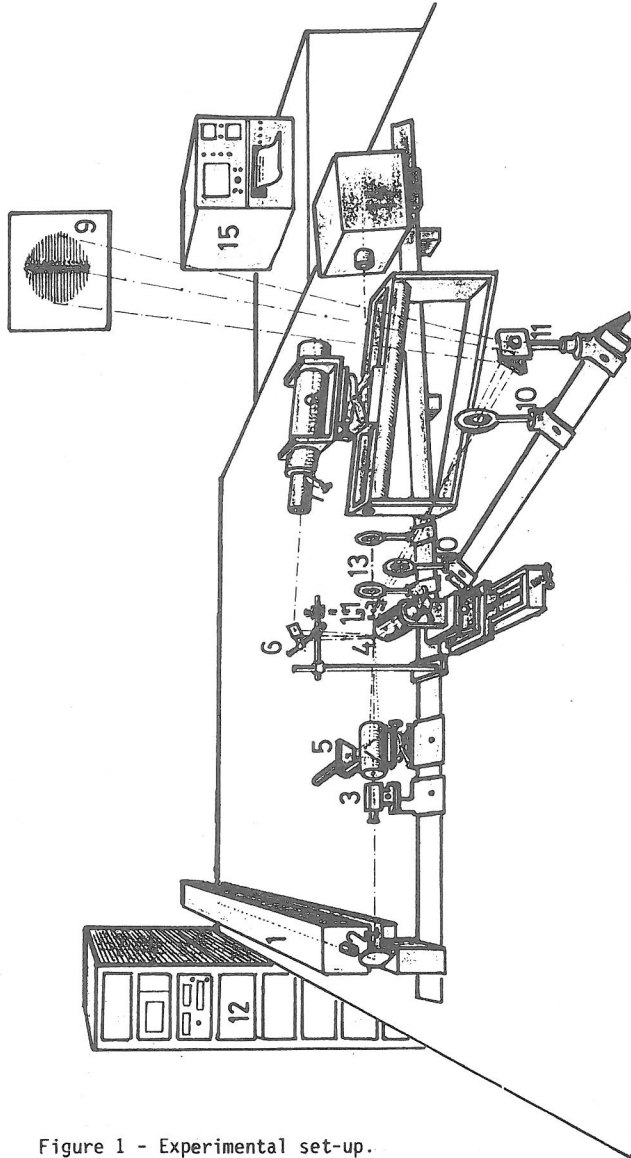

Figure 1 - Experimental set-up.

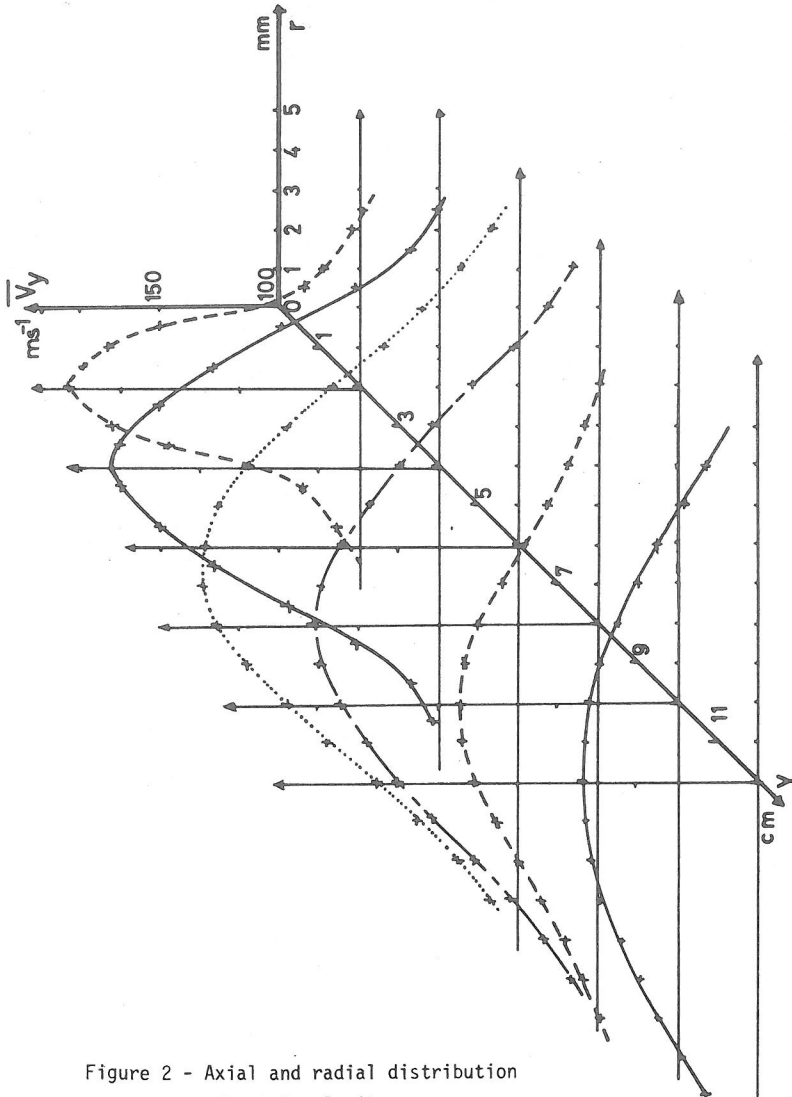
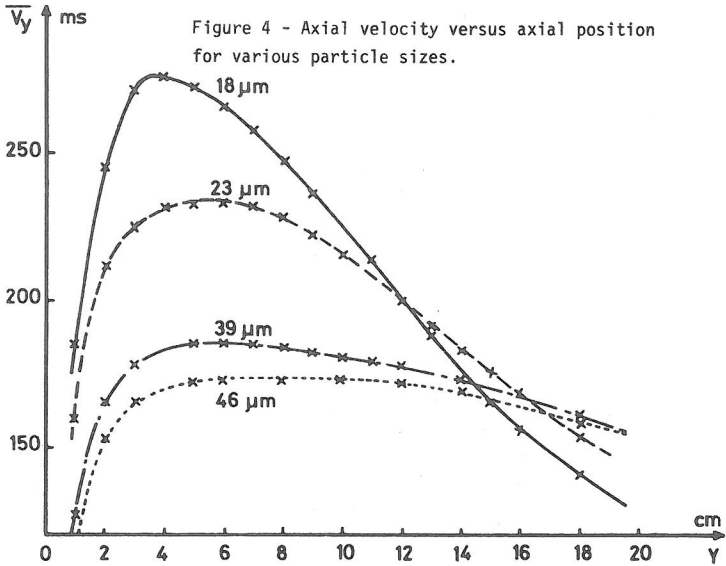
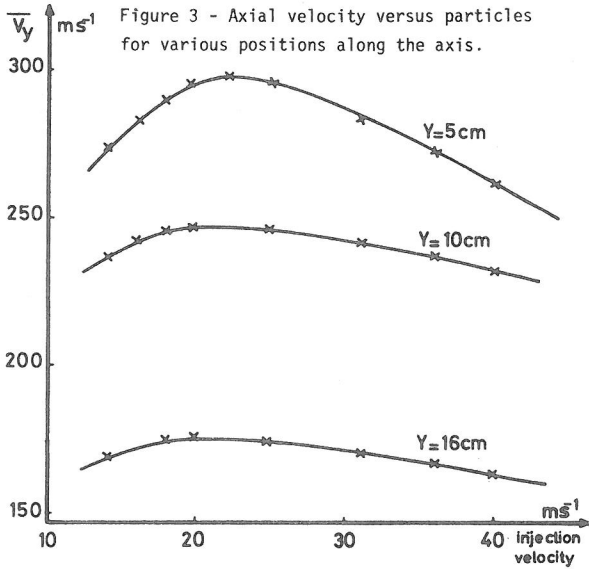

Figure 2 - Axial and radial distribution of axial velocity.



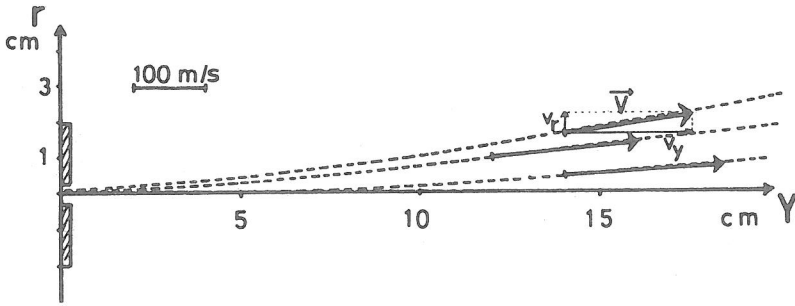

Figure 5 - Particles paths.

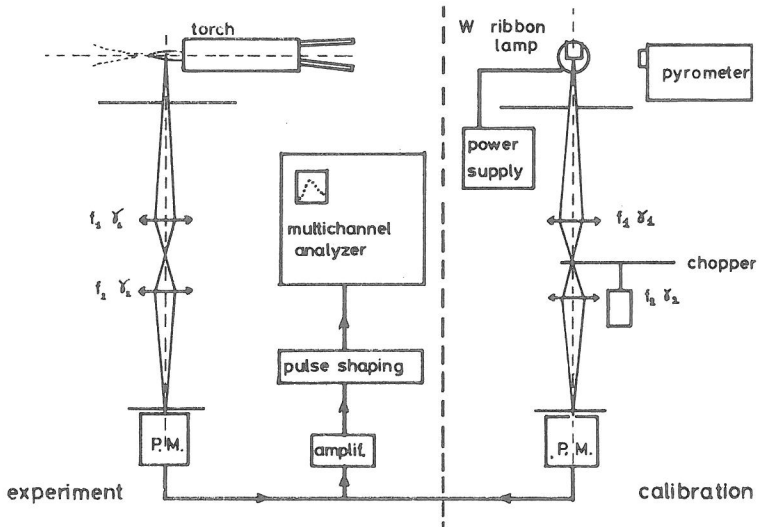

Figure 6 - Experimental set-up for surface temperature measurement.

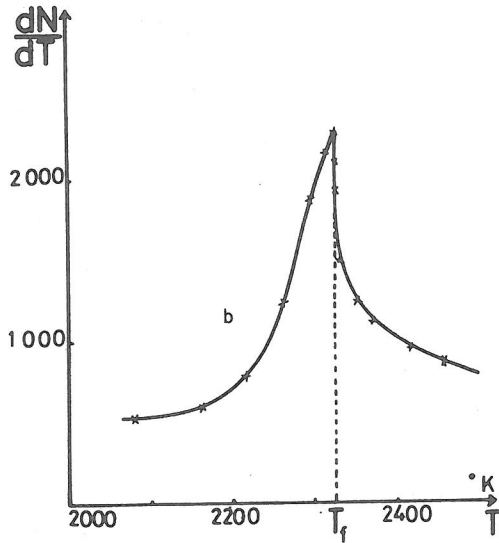
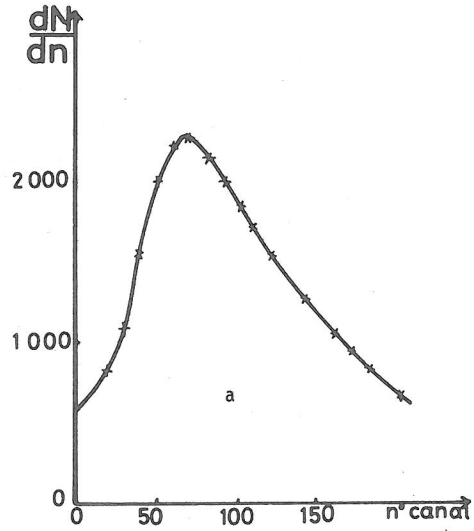

Figure 7 - Particles surface temperatures histogram.

