

Comparison of Ozone Generation Characteristics by Filamentary Discharge Mode and Townsend Discharge Mode of Dielectric Barrier Discharge in Oxygen

Y. Nakai¹, A. Takashi¹, N. Osawa¹, Y. Yoshioka², R. Hanaoka¹

¹*Department of Electrical and Electronic Engineering, Kanazawa Institute of Technology*

²*Office of Industry-University Collaboration, Kanazawa Institute of Technology*

Abstract: The Dielectric Barrier Discharge (DBD) is widely used for ozone generation, exhaust gas treatment, surface treatment etc. In our laboratory, we investigated efficient cleaning methods of diesel exhaust gas by DBD. In 2008, we found that a novel Atmospheric Pressure Townsend Discharge (APTD) was generated in air using alumina barrier plates. In this study, using two ozonizers with different discharge modes, we investigated the effects of discharge mode and gas components to the ozone generation performance. The experiment results showed a peculiar effect that the ozone yields by APTD were almost the same in air and in pure oxygen. We are now thinking that in case of APTD mode, the electrons cannot get enough energy to dissociate O₂ efficiently.

Keywords: ozone generation, filamentary discharge, Townsend discharge.

1. Introduction

The Dielectric Barrier Discharge (DBD) is widely used for ozone generation [1], exhaust gas treatment [2], surface treatment etc. In our laboratory, we investigated efficient cleaning methods of diesel exhaust gas by DBD. As for NO_x removal, O radical and O₃ which are generated by electrical discharge are an oxidation agent of NO to NO₂. Therefore, the NO_x removal performance is governed by the generation processes of O radical and O₃. So far, we developed the program which calculates the plasma chemical reactions of NO removal. Using this program, we found that the NO removal efficiency was governed by diffusion process of radicals, which were generated in the center of Filamentary micro-Discharge (FD) columns. Therefore, we considered if a homogeneous DBD is available, the efficiency of NO_x removal and also ozone generation may increase. So far, it is reported that there are two kinds of homogeneous DBDs. One is an Atmospheric Pressure Glow Discharge (APGD) and the other is an Atmospheric Pressure Townsend Discharge (APTD). In the literature [3], it was reported that the ozone yield by APGD is higher than that by typical DBD. In 2008, we found that a novel APTD was generated in air using alumina barrier plates [4]. Using this APTD, we investigated the difference of ozone yields by FD mode and by APTD mode [5]. The results showed that (1) the maximum ozone yield by FD mode was higher than that by APTD mode. (2) The maximum ozone yield by APTD mode was 52g/kWh, and the ozone yield began to decrease rapidly with the increase of the specific input energy (Joule/Liter). Here, the specific

input energy is defined as the energy input to a unit gas volume. Namely it is a ratio of the discharge power to the gas flow rate. (3) However, although the maximum ozone yield by APTD mode was 23g/kWh, the yield was almost constant even at higher specific input energy. Therefore we considered if we used oxygen as source gas of ozone generation, the ozone yield may increase.

In this study, we investigated the effect of gas components to the ozone generation performance.

2. Experimental system

2.1 Experimental setup

Fig.1 shows experimental setup for ozone generation. AC high voltage was applied to a parallel plane type DBD ozonizer by a setup transformer (ratio of transformer 1:150). Frequencies of the applied voltage were from 200 to 600Hz, and the maximum applied voltage was 31.2kVp. The applied voltage and the current were measured by an oscilloscope (Tektronix TDS 2024B, 200MHz, 2.0GS/s) using a H.V. probe (Pulse Engineering EP-50K, 1/2000) and a differential probe (Yokogawa Electric Corporation 700924, 100MHz). An integral of the current was measured from the voltage drop across an integral capacitor. Besides, the discharge power was calculated by multiplying the area of V - q lissajous figure by power frequency. In this system, air and pure oxygen were used as source gas. They supplied by an air pump or gas cylinder and the flow rate was fixed to 2.0L/min. Ozone concentration was measured by an ozone monitor (Ebara jitsugyo EG 2001-B).

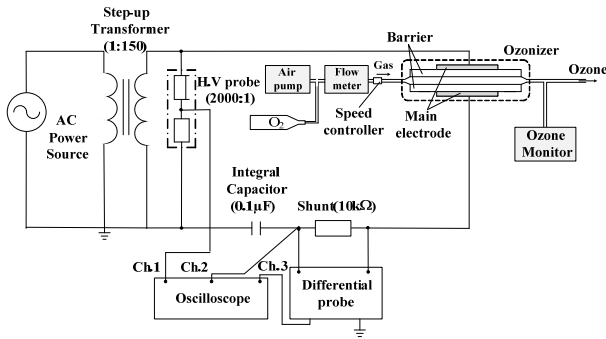
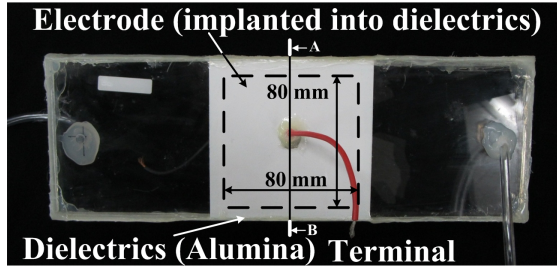
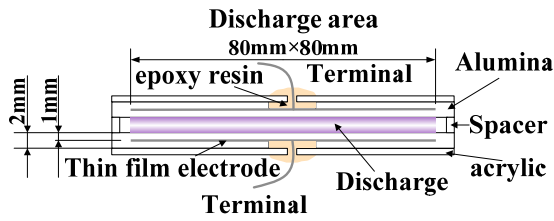

Fig. 1. Experimental setup.



(a) Electrode: thin tungsten film, dielectrics: alumina (Kyocera A473), discharge mode: APTD.



(b) Cross-sectional view of the reactor along the line A-B.
Fig. 2. Picture and size of parallel plane DBD type ozonizer.

2.2 Ozonizer

Fig.2 shows the parallel plane type DBD ozonizer. We used 2 kinds of barrier material, namely, a soda-glass and alumina (Kyocera Corporation, type A473). The soda-glass generates the FD, and the A473 alumina generates the APTD. Thicknesses of barriers are 3.2mm and 1.0 mm respectively. These ozonizers have a discharge gap spacing of 2mm and electrode area of 64cm^2 ($=80\text{mm}\times 80\text{mm}$).

3. Results and discussions

3.1 FD and APTD in air and oxygen

Fig.3 (a)-(c) and Fig.4 (b)-(d) show waveforms and discharge photographs by FD and by APTD modes. In this experiment, the applied voltage to the ozonizer was 16kV_p (200Hz). In case of air, the exposure time of digital camera was 2s (photograph (b) and (c)). On the other hand, in case of O_2 , the exposure time was 30s because luminosity from the discharge area was very weak. In Fig.3 (a), we can see that the current wave form had many pulses. In Fig.4 (b), we can recognize many FDs. This discharge is the typical DBD. On the other hand, in Fig.3 (b), we can see that the current waveform has

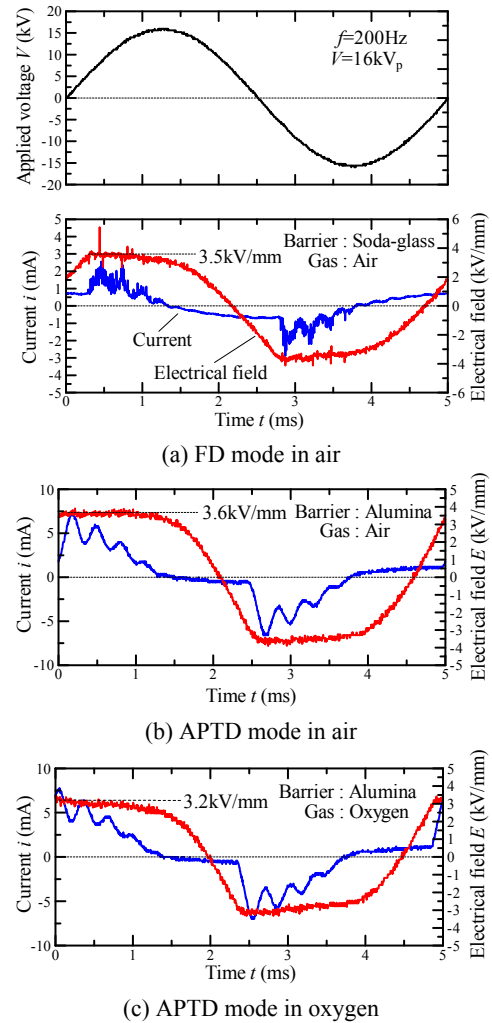
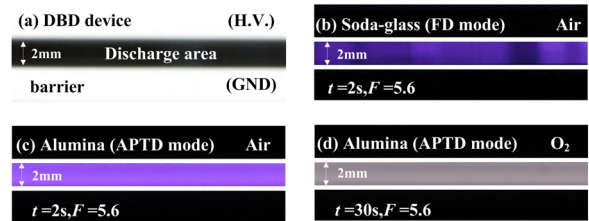

Fig. 3. The applied voltage, current and electrical field in air and oxygen at atmospheric pressure.



(t is the exposure time and the F is the aperture of the lens)
Fig. 4. Discharge photographs of FD and APTD.

no pulse. In Fig.4 (c), we can see that the discharge is homogeneous. Next, Fig.3 (c) shows the current waveform recorded by the discharge in pure oxygen. The current waveform is almost same as that in Fig.3 (b). In Fig.4 (d), we can see that the discharge is homogeneous. In our previous research, we concluded that the homogeneous discharge in air is the APTD. Therefore, the homogeneous discharge in oxygen also seems to be the APTD. Next, we investigated the effect of discharge mode and gas components to the ozone generation.

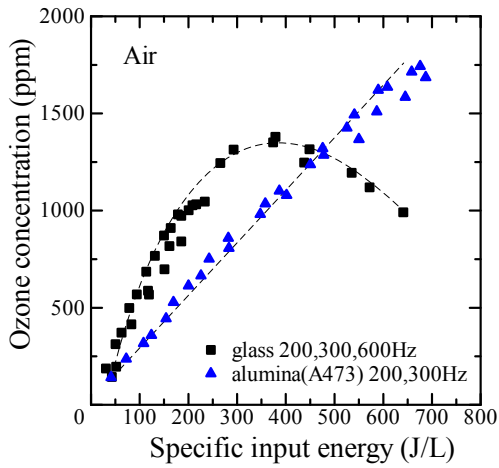

Fig. 5. Ozone concentration versus the specific input energy for two discharge modes in air.

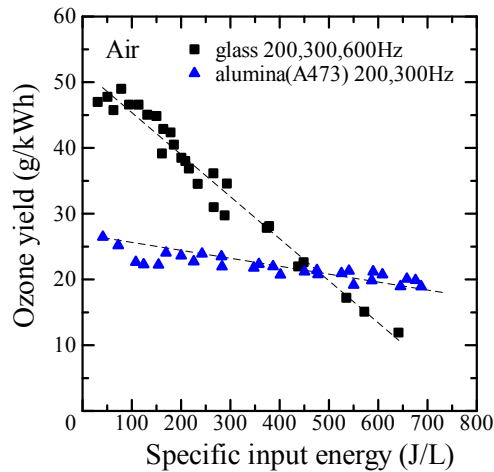

Fig. 6. Ozone yield versus the specific input energy for two discharge modes in air.

3.2 Ozone generation performance by APTD in air

Fig.5 shows a relation between the ozone concentration and the specific input energy by two discharge modes in air. The ozone concentration by FD mode increased with the increase of the specific input energy, but it reached the maximum at the specific input energy of 378J/L. The maximum ozone concentration of this experiment was 1379ppm. Then, the ozone concentration decreased with the further increase of specific input energy and it attained 991ppm at 641J/L. On the other hand, the ozone concentration by APTD mode increased with the increase of the specific input energy. The maximum ozone concentration was 1743ppm at 675J/L. Namely, at a low specific input energy region (30J/L-450J/L), the ozone concentration was higher by FD mode than by APTD mode. However, at a high specific input energy region (450J/L-736J/L), the ozone concentration was higher by APTD mode than by FD mode.

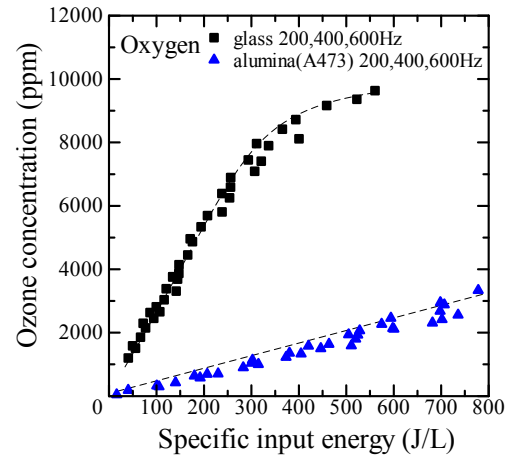

Fig. 7. Ozone concentration versus the specific input energy for two discharge modes in oxygen.

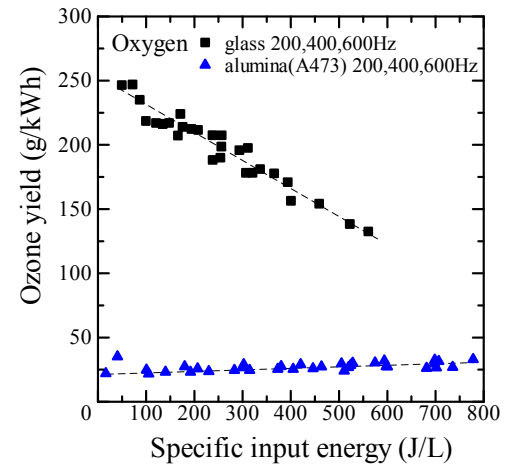
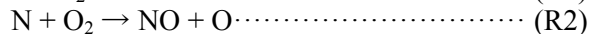
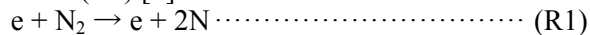

Fig. 8. Ozone yield versus the specific input energy for two discharge modes in oxygen.

Fig.6 shows a difference of the ozone yields by two different discharge modes in air. The maximum ozone yield by FD mode was 49g/kWh at the specific input energy of 78J/L. However, the ozone yield decreased rapidly with increase the specific input energy and it attained to the minimum value of 11.9g/kWh at 641J/L. On the other hand, the maximum ozone yield by APTD mode was 26g/kWh at the specific input energy of 41J/L. The ozone yield decreased slightly with the increase of the specific input energy and it attained to the minimum value of 18.9g/kWh at 687J/L. Therefore, at a low specific input energy region, the ozone yield was higher by FD mode than by APTD mode. However, at a high specific input energy region, the ozone yield was higher by APTD mode than by FD mode.

Here, we discuss why ozone yield by APTD mode was lower than that of by FD mode. The reason seems to be as follows. Since we used air as source gas of ozonizer, nitrogen oxides (NO_x) are generated

by electrical discharge (R1) and by the N atom reactions (R2) [6].



O radical and O₃ are destructed by reacting with NO and NO₂.

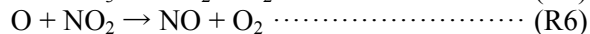
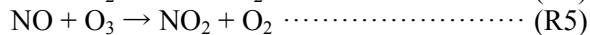
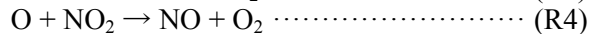

Besides, it is well known that the O₃ is also destructed by electron impact [7].

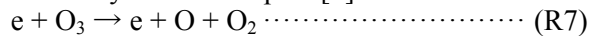

However, generation of O radicals and ozone reactions are as follows [7];

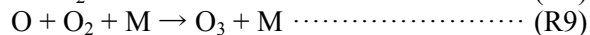
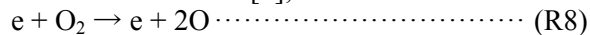

Generally, the ozone generation performance of an air fed ozonizer was decided by a rate of O₃ destruction and a rate of O₃ generation. In case of the APTD mode, it is considered that O radicals were not generated so much by electron impact (R8), or O radicals and O₃ were consumed by NO_x (R3-6) and electron impact (R7). In order to confirm the effect of NO_x, we used oxygen as source gas of the ozonizer. In this case, the NO_x generation and subsequent O radicals and O₃ destruction reactions can be prevented.

3.3 Ozone generation performance by APTD in O₂

Fig.7 shows the relation between ozone concentration and the specific input energy by two different discharge modes in pure oxygen. The ozone produced by FD mode increased with the increase of the specific input energy. However, it saturated at the specific input energy higher than 310J/L and it attained to the maximum ozone concentration of 9634ppm. On the other hand, the ozone produced by APTD mode increased with the increase of the specific input energy and the maximum ozone concentration was 3335ppm at 778J/L. Fig.8 shows the ozone yields by two different discharge modes in pure oxygen. As for FD mode, the maximum ozone yield of 247g/kWh was obtained at the specific input energy of 71J/L. However, the ozone yield decreased rapidly with the increase of the specific input energy and it attained to the minimum value of 132g/kWh at 560J/L. On the other hand, as for APTD mode, the ozone yield increased slightly with increase the specific input energy and it attained to 33g/kWh at 778J/L.

Here, we discuss why the ozone yield by APTD mode is almost the same as that obtained by the air fed ozonizer, despite the absence of NO_x generation. We are now thinking that because the APTD is not a

streamer discharge, the electrical field strength in the APTD is much lower than the local electrical field in the FD. Therefore the electrons cannot get enough energy to dissociate O₂ (R8). Next, we discuss why the ozone yield by the air fed ozonizer decreases slightly with the increase of the specific input energy. In case of the air fed ozonizer, higher specific input energy enhances a formation of NO_x (R1, R2). Then, O radical and O₃ are soon reacted with NO and NO₂. (R3-6). However in case of oxygen, higher specific input energy enhances the generation of O radicals and the formation of O₃ (R8, R9).

4. Conclusions

We setup a parallel plane type DBD ozonizer with two discharge modes and investigated the effect of gas components and discharge mode to ozone generation. The experimental results obtained are as follows;

(1) In case of oxygen fed ozonizers, the ozone yield by FD mode was 247g/kWh, however it decreased rapidly with the increase of the specific input energy and it attained to the minimum value of 132g/kWh at 560J/L. On the other hand, the ozone yield by APTD mode increased slightly with the increase of the specific input energy and it attained to the maximum ozone yield of 33g/kWh at 778J/L.

(2) In case of APTD mode, the maximum ozone yield of the oxygen fed ozonizer was 33g/kWh which is almost the same as that obtained by the APTD mode air fed ozonizer. The maximum ozone yield by APTD did not changed by the gas components.

Acknowledgements

We would like to thank Kyocera Corporation for assistance in the supply of A473 alumina barrier plates.

Reference

- [1] C. Yamabe, IEEJ Trans FM, **126**, 874 (2006).
- [2] Y. Yoshioka, J. plasma Environmental Sci. and Technol., **1**, 110, (2007).
- [3] M. Kogoma, S. Okazaki, J. Phys. D: Appl. Phys., **27**, 1985 (1994).
- [4] N. Osawa, Y. Yoshioka, R. Hanaoka, Y. Mochizuki and Y. Yamada, IEEJ Trans FM, **130**, 306 (2010).
- [5] N. Osawa, H. Kaga, Y. Fukuda, S. Harada, Y. Yoshioka and R. Hanaoka, Proc. of The 12th Int. Symp. High pressure Low Temperature Plasma Chem. (HAKONE XII), 282 (2010).
- [6] C. Yamabe, J Plasma and Fusion Res., **74**, 134 (1998).
- [7] N. Tabata, J Plasma and Fusion Res., **74**, 1119 (1998).